

FLOSYS WATER SOLUTIONS PVT. LTD.

GIVING WORLD A BETTER TOMORROW
HIGH PURITY WATER SYSTEMS & EQUIPMENTS

ABOUT FLOSYS WATER SOLUTIONS

Flosys Water Solutions was founded in 2019, Being one of the pioneer companies in manufacturing of water and wastewater treatment plants is now one of the leading India Pharmaceuticals, Dairy and Food Equipment Manufacturer.

From Waste water treatment to manufacturing High Purity Water Systems. Flosys has accumulated unparallel wealth of technology and knowhow.

OUR VISION

Flosys Water Solutions Pvt. Ltd. Will be the most respected and valued company in global High Purity Industry in the eyes of its customers, employees and the Communities in which we work.

OUR MISSION

To be one of the most trusted partners and solution provider to the industry for integrated systems and components, high on quality yet cost effective with the primary objective of setting standards with constant.

OUR TEAM

We have assembled teams of engineers, skilled workers and technicians after following stringent hiring processes. Our members are highly experienced. The entire production process is flawlessly carried out under supervision of skilled engineers & technicians. Further the Quality auditors working with us assist us in checking incoming material on various parameters before the final dispatch. Process thus ensuring optimum operational standards of equipment supplied from our end.

INDUSTRIES WE SERVE

Pharmaceuticals
Textile
Food & Beverages
Hospitals
Automobile
Cosmetics
Etc.



MULTIGRADE SAND & ACTIVATED CARBON FILTER (MGF & ACF)

Our Company is a prominent manufacturer of multigrade & Activated carbon filter in India and provide Engineering Services from designing, manufacturing to installing and commissioning. Our multigrade & Activated Carbon Filtration plants are designed to meet specific requirements of our customers, no matter what quality of water you use and what your flow rate requirements are, our w=engineering team is capable of configuring the same accordingly from 1000 LPH to 50000 LPH. We can manufacture and supply any capacity you need. MGF & ACF can be a part of a total water treatment solution, MGF & ACF systems are designed especially for your application using either fiberglass, PVC, lined carbon Steel or Stainless Steel in the materials of construction.



SOFTENERS

Flosys Water Solutions Pvt. Ltd. Water Softeners are designed for the removal of hardness, ammonia or both. The softeners are designed based on your water quality required and the feed water analysis. High hardness in the water results in a number of maintenance issues downstream to equipment's like boilers, cooling towers, Ro Plant etc. Softeners can be provided individually or as part of a total water treatment solutions. The control system for the water softener can be dedicated to the softener or total system. Softener systems are designed especially for your application using either fiberglass, PVC lined carbon steel or Stainless Steel in the materials of construction. Flosys Water Solutions can customize the plants as per a wide variety of clients requirements and yet assure hardness of less than 5 PPM at the outlet of its softeners.



ULTRA-FILTRATION SYSTEMS

Flosys Water Solutions Pvt. Ltd. UF systems are designed for removal of Suspended Solids including bacteria, endotoxins and high weight molecules. This level of filtration offers many advantages, including reduced fouling of any downstream RO membranes and lower endotoxin for purified/WFI water. The Membranes filters can be provided individually or as part of a total water solution. The control system for the membranes filters can be dedicated to the filter system or part of a total water system. Hollow Fiber membranes construction allows reverse flow backwash cycles to remove the accumulation of filtered solids.

99% removal for suspended solids
Endotoxin/Bioburden reduction.
0.5 Ra SS316L electro-polished permeate.
PLC based control.



PORTABLE RO WATER

Reverse Osmosis (RO) systems from Flosys Water Solutions offers a cost effective and sustainable solution for generating high purity water. Our portfolio of industrial reverse osmosis (RO) system includes those specifically engineered and designed for large industrial applications, medium sized commercial applications and small laboratory application. RO system can achieve TDS as low as upto 01 ppm for multiple applications such as drinking, industrial, washing, paint shop, boilers feed, utilities etc.

Fully automatic Design
SS-304/316 Skid.
High efficiency Cleaning system.
Heat Sanitizable Hot Water & Steam arrangement.
PLC based Control.

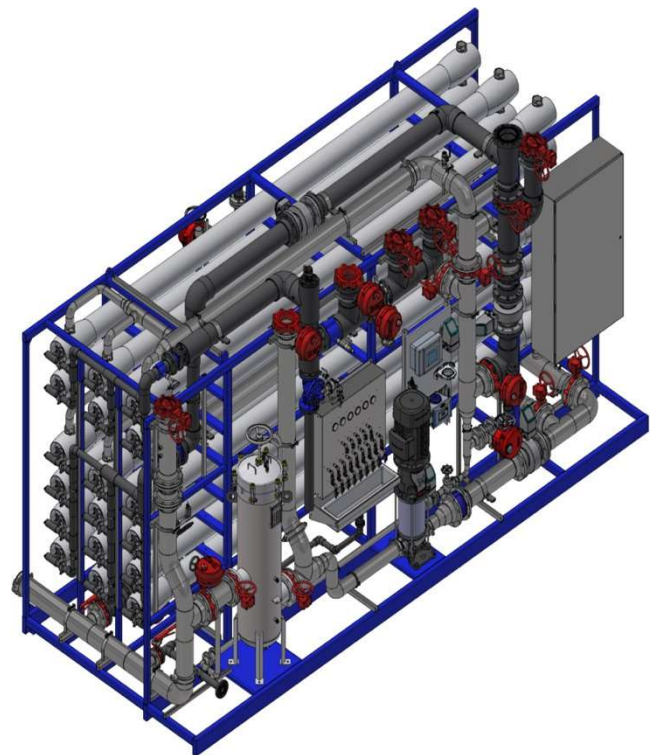

HIGH PURITY WATER SYSTEM RO-EDI SYSTEM

High Purity RO-EDI system from Flosys Water Solutions offers a cost effective and sustainable solution for generating the high purity water with conductivity of $< 1.2\mu\text{S}/\text{cm}$. to suits the client requirement for product quality. Flosys water designs a system based on hot water & chemical sanitization RO-EDI. We provide the wide range of flow rate for laboratory, R&D centers & industrial large scale.

Customized to meet the customer requirement.
Designed to meet USP/EU Pharmacopeia & cGMP.
High Efficiency Cleaning system
Durable Stainless-Steel Construction
PLC based control System
SS-304 Skid.
All Required safety interlocks.



PURE WATER / WATER FOR INJECTION STORAGE & DISTRIBUTION SYSTEM

Flosys Water is one of the pioneer in Pure Water/Water for Injection/Pure water Storage & distribution systems in designing, manufacturing & installation storage & distribution system. Flosys Water can design a system based on client requirements, peak load requirement.

Complete system designed to meet current USP/BP/EU pharmacopoeia standard and cGMP requirement.
Unit is completely piped, wired & factory assembled on skid at the factory to reduces the installation cost & startup time.
Distribution pumps are provided with VFD.
PLC based Control or SKADA on Demand Available
All required Safety Interlocking.



UTILITY PIPING & CLEAN ROOM PENDENTS

SS-316 L Pure Steam Piping.
SS316L/SS304 CIP/SIP Piping
SS316L/SS304 compressed air Piping.
SS316L/SS304 portable Water piping.
SS326L/SS304 Nitrogen Piping.
SS316L/SS304 Vacuum Piping.
SS316/SS304 Interconnecting product piping.
Clean Room Utility Pendent
Orbital Welding on Demand.



FLOSYS

Flosys Water Solutions Pvt. Ltd.

H-25, S 16, 2nd Floor, Sector-63, Near Electronic City Metro Station, Noida,
Gautam Budh Nagar, Uttar Pradesh - 201301.

Mob. - +91-8295548879 / 9911825510

Email Id. - info@fwspl.com;

Web: - www.fwspl.com